

DATASHEET

EOLD-980-015-1



980 nm IR LED in TO-can with glass lens

Features:

- TO-46
- Glass Lens with 10° view angle
- Size: 20 mm (total length)
 - 4.7 mm (cap diameter)
 - 5.36 mm (header diameter)
- ROHS and REACH compliant
- Lead-free solderable

Applications:

- Sensing
- Biometric Security
- Medical
- Machine Vision

Typical Electro-Optical Characteristics

Measurement conditions

 $T_{\text{ambient}} = 23\text{ °C}$; $t_{\text{test}} \leq 60\text{ ms}$

Parameter	Symbol	Condition	Min	Typ	Max	Unit
Emitting Color				Infrared		
Forward Voltage	V_f	$I_f = 100\text{ mA}$		1.5	2.0	V
Peak Wavelength	λ_p	$I_f = 100\text{ mA}$	960	980	1000	nm
FWHM	$\Delta\lambda$	$I_f = 100\text{ mA}$		46		nm
Radiant Power	Φ_e	$I_f = 100\text{ mA}$	12	23		mW
View Angle	θ	$I_f = 100\text{ mA}$		10		deg.
Reverse Current ⁽¹⁾	I_R	$V_R = 5\text{ V}$			10	μA

⁽¹⁾ Tested on chip level**Maximum Ratings**

Parameter	Symbol	Min	Max	Unit
Forward Current	$I_{f, \text{max}}$		100	mA
Reverse Voltage	V_R		5	V
Soldering Temperature	$\leq 3\text{ s}$	T_{Sol}	350	$^{\circ}\text{C}$
Operating Temperature	T_{op}	-40	85	$^{\circ}\text{C}$
Storage Temperature	T_{st}	-40	100	$^{\circ}\text{C}$



Typical Performance

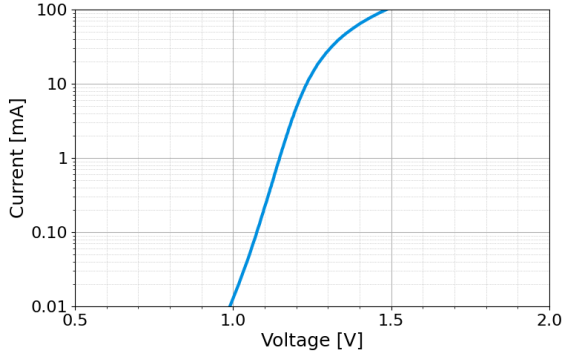

Current vs. Forward Voltage

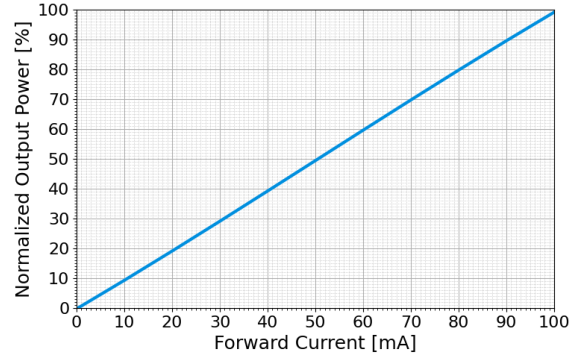

Relative Intensity vs. Forward Current

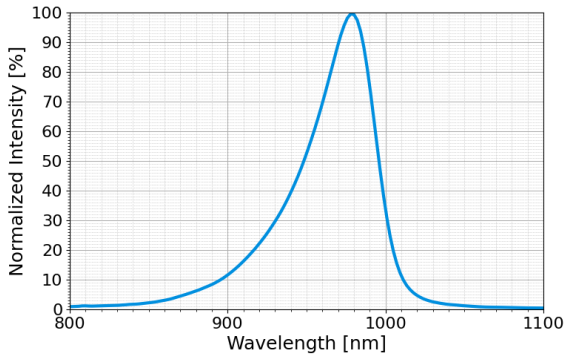

Optical Spectrum (at 100 mA)

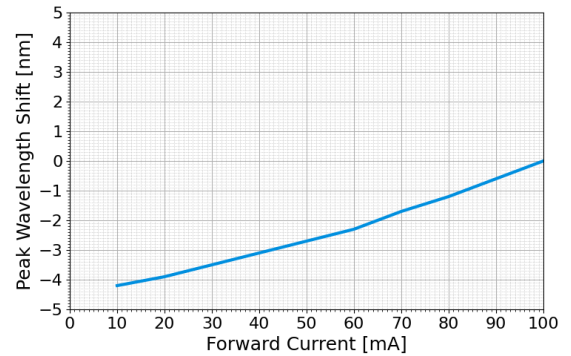

Wavelength Shift vs. Forward Current

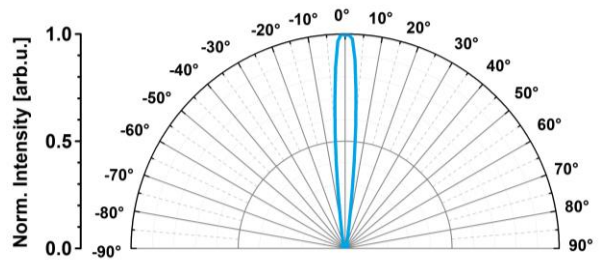

Radiation Pattern

Outline Drawing

Unless otherwise specified, all drawing units are in mm
Tolerances are: ISO 2768-m

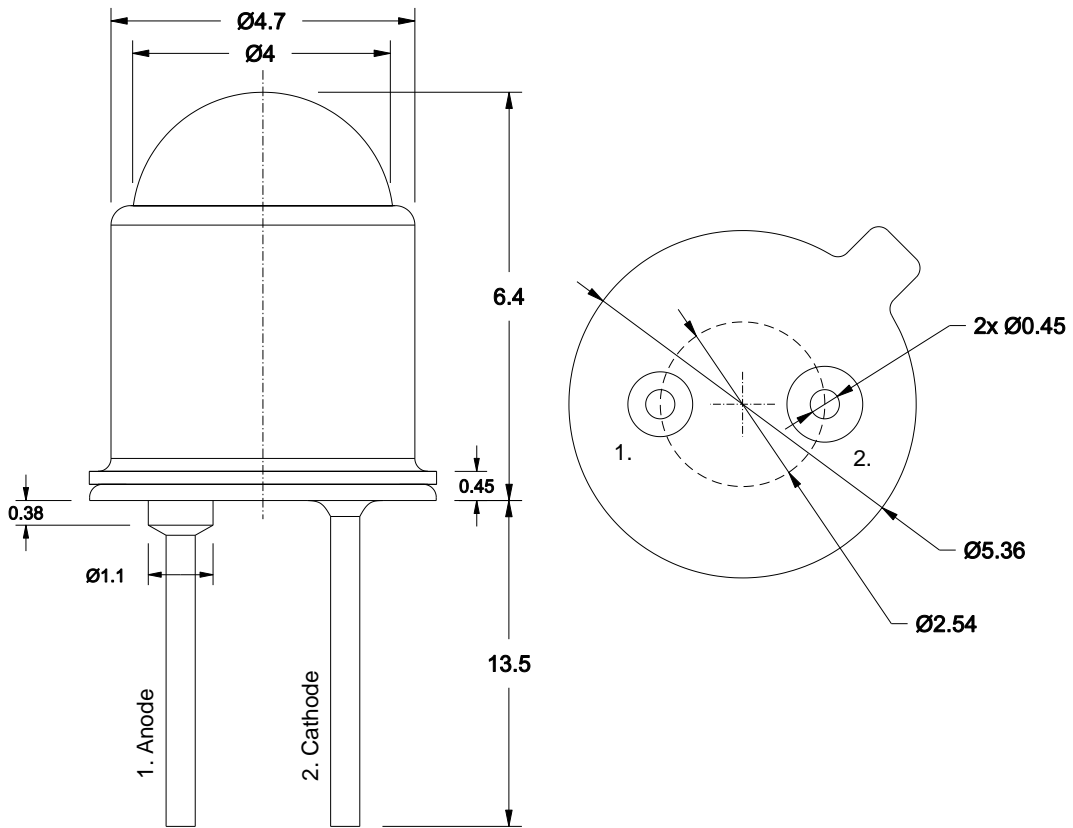

Pin 1 – Anode
Pin 2 – Cathode

Notice

The information describes the type of component and shall not consider as assured characteristics. Terms of delivery and rights to change reserved. The data sheet may change without prior notification; the only valid issue and current revision can be on our website. Due to technical requirements, components may contain dangerous substances.

It is the responsibility of the customer to evaluate and ensure that the use of the products in their specific applications complies with relevant safety standards and regulations. Customers must assess the exposure conditions within their systems and ensure that appropriate measures are taken to prevent exceeding the permissible exposure limits outlined in IEC 62471. EPIGAP OSA Photonics GmbH does not assume liability for any non-compliance arising from the integration or usage of LEDs in customer systems.

Parameters can vary in different applications. The customer must validate all operating parameters for each application. EPIGAP OSA Photonics GmbH does not have the responsibility for the reliability and the degradation behavior of products made with EPIGAP OSA Photonics GmbH diodes as they depend not only on the product itself but also on the operation, manufacturing or design of the final products. The customer is responsible to ensure the long-term stability of the product according to their requirements. If components are used in toys or, life support systems, EPIGAP OSA Photonics GmbH must expressly authorize the use of the components prior to incorporating them into the customer's systems!
Packaging: EPIGAP OSA Photonics GmbH uses recyclable packages.

EPIGAP OSA Photonics GmbH

www.epigap-osa.de

Köpenicker Str.325
12555 Berlin Germany
Tel. +49 (0)30 6576 3764
sales@epigap-osa.de

